

ERRATA NOTES

CC1101

Table Of Contents

1	RX FIFO	2
2	PLL LOCK DETECTOR OUTPUT	3
3	SPI READ SYNCHRONIZATION ISSUE	4
4	WOR TIMING ERROR ON SHORT TIMING INTERVALS	7
5	RXFIFO_OVERFLOW ISSUE	8
6	EXTRA BYTE TRANSMITTED IN TX	10
7	DOCUMENT HISTORY	11

1 RX FIFO

1.1 Description and Reason for the Problem

If a received data byte is written to the RX FIFO at the exact same time as the last byte in the RX FIFO is read over the SPI interface, the RX FIFO pointer is not properly updated and the last read byte is duplicated.

1.2 Suggested Workaround

For packets below 64 bytes, it is recommended to wait until the complete packet has been received before reading it out. If this is not possible or the packet is longer than 64 bytes, it is recommended to use the following workaround:

The number of bytes in the RX FIFO can be read from the status register `RXBYTES.NUM_RXBYTES`. To avoid receiving data while reading the last byte in the RX FIFO one should never empty the RX FIFO before the last byte of the packet is received. Due to issue 3 in this errata note, special care must be taken when reading the `RXBYTES` register during reception.:

1. Read `RXBYTES.NUM_RXBYTES` repeatedly at a rate specified to be at least twice that of which RF bytes are received until the same value is returned twice; store value in *n*.
2. If $n < \#$ of bytes remaining in packet, read $n-1$ bytes from the RX FIFO.
3. Repeat 1-2 until $n = \#$ of bytes remaining in packet.
4. Read the remaining bytes from the RX FIFO.

Pseudocode:

```

BYTE n, l, len, *pDataBuf;

// Get length byte in packet (safely)
n = SPI_READ(RXBYTES);
do { l = n; n = SPI_READ(RX_BYTES); } while (n<2 && n!=1);
*pDataBuf++ = len = SPI_READ(RX_FIFO);

// Copy rest of packet (safely)
while (len>1) {
    n = SPI_READ(RXBYTES);
    do { l = n; n = SPI_READ(RX_BYTES); } while (n<2 && n!=1);
    while (n>1) {
        *pDataBuf++ = SPI_READ(RX_FIFO);
        len--; n--;
    }
}
*pDataBuf++ = SPI_READ(RX_FIFO);

```

1.3 Batches Affected

This errata note applies to all batches and revisions of the chip.

2 PLL Lock Detector Output

2.1 Description and Reason for the Problem

The PLL lock detector output is not 100% reliable and might toggle even if the PLL is in lock. The PLL is in lock if the lock detector output has a positive transition or is constantly logic high. The PLL is not in lock if the lock detector output is constantly logic low. It is not recommended to check for PLL lock by reading `PKTSTATUS[0]` with `GDOx_CFG=0x0A` or `PKTSTATUS[2]` register with `GDOx_CFG=0x0A` ($x = 0$ or 2).

2.2 Suggested Workaround

PLL lock can be checked reliably as follows:

1) Program register `IOCFGx.GDOx_CFG=0x0A` and use the lock detector output available on the GDOx pin as an interrupt for the MCU. A positive transition on the GDOx pin means that the PLL is in lock. It is important to disable for interrupt when waking the chip from SLEEP state as the wake-up might cause the GDOx pin to toggle when it is programmed to output the lock detector.

or

2) Read register `FSCAL1`. The PLL is in lock if the register content is different from `0x3F`.

With both of the above workarounds the CC1101 PLL calibration should be carried out with the correct settings for `TEST0.VCO_SEL_CAL_EN` and `FSCAL2.VCO_CORE_H_EN`. These settings are depending on the operating frequency, and is calculated automatically by SmartRF® Studio.

It must be noted that the `TEST0` register content is not retained in SLEEP state, and thus it is necessary to write to this register as described above when returning from the SLEEP state.

2.3 Batches Affected

This errata note applies to all batches and revisions of the chip.

3 SPI Read Synchronization Issue

A bug affecting the synchronization mechanism between the SPI clock domain (using a user supplied SCLK) and the internal 26 MHz clock domain (XCLK in this document) will sometimes result in incorrect read values for register fields that are continuously updated. The frequency with which this occurs is very low and guidelines for application design to avoid this issue are given in this chapter. The issue does **not** affect the data read from the RX FIFO as it uses a different and more robust synchronization mechanism. Neither does the issue affect writes to registers or the TX FIFO at any time.

3.1 Symptoms

When reading multi-bit register fields that are updated by the radio hardware such as the `MARSTATE` or `TXBYTES` registers over the SPI interface, occasionally nonsensical or erroneous values will be read.

For example, in an application that sends packets longer than the 64 byte TX FIFO, the TX FIFO must be topped up with additional data during packet transmission. Assuming this is done by initially transferring 64 bytes to the TX FIFO, starting transmission, and then continuously polling `TXBYTES` to see when space for additional bytes is available, and then transferring the required number of bytes until the end of the packet. In this case the expected sequence of values read from `TXBYTES` would be:

64, 64, ..., 63, (write byte), 64, 64, ..., 63, (write byte), 64, ...

Due to the SPI synchronization issue the following might (infrequently) be seen instead:

64, 64, ..., 63, (write byte), 64, 64, ..., 64, **89**, 63, ...

The erroneous value read is highlighted in red. The register read is changing from the value 64 (`01000000b`) to the value 63 (`00111111b`) on the XCLK clock at the same time that its value is latched into the SPI output shift register on the SCLK clock. If the two clock edges occur sufficiently close in time, the improper synchronization mechanism will latch some bit values from the previous register value and some bits from the next register value, resulting in the erroneous value 89 (`01011001b`).

3.2 Description

During an SPI read transaction, the SPI output register latches the read value on the last falling edge of SCLK during an SPI address byte. For a burst read operation, subsequent register values are latched on the falling edge of SCLK in the last bit of each previous data byte.

Due to this synchronization issue, if the register being read changes value (synchronously with XCLK) during a certain period of time after this falling edge of SCLK then some of the bits in the read value will come from the `previous` value and some from the `next` value. This so-called window of uncertainty is about 1.3 ns for typical conditions and increases to about 2.0 ns for worst-case conditions (1.8 V VDD, 85 °C).

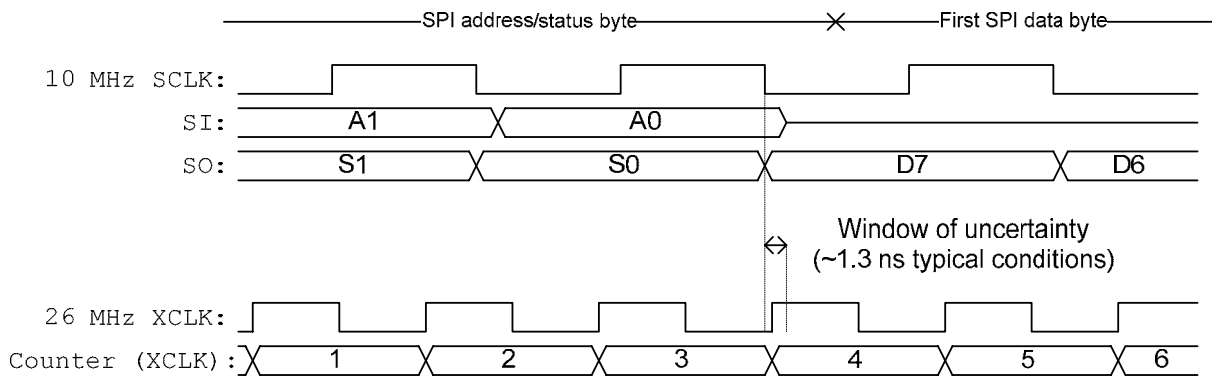

Figure 1: Window of Uncertainty (drawing not to scale)

Figure 1 shows a timing diagram of an SPI read that fails when reading a fictitious counter being updated internally each **XCLK**. Since the counter update from value **3** (011b) to **4** (100b) within the window of uncertainty, the read value could be any one of 0-7 (000b, 001b, 010b, 011b, 100b, 101b, 110b, 111b) depending on exactly when the positive edge of **XCLK** falls within the window of uncertainty.

3.2.1 What Kinds of Register Fields Are Affected?

This issue does **not** affect:

- Reading of received data from the RX FIFO at any time.
- Reading of the static configuration registers (registers 0x00-0x2E)
- Reading static status registers (`PARTNUM`, `VERSION`) or status registers whose values should only be read after packet reception/transmission or FS calibration (`FREQEST`, `LQI`, `VCO_VC_DAC`)
- Single-bit fields (all fields in `PKTSTATUS`, `TXBYTES.TXFIFO_UNDERFLOW`, `RXBYTES.RXFIFO_OVERFLOW`)
- Reading of any register whose value is known not to change at the time of the read operation (e.g. reading `RXBYTES` or `RSSI` after having received a packet)

This issue **does** affect:

- The SPI status byte (shifted out while the host MCU supplies the address byte) fields `STATE` and `FIFO_BYTES_AVAILABLE`.
- Reading `FREQEST` or `RSSI` while the receiver is active.
- Reading `MARCSTATE` at any other time than when the device is inactive (IDLE).
- Reading `RXBYTES` when receiving a packet or `TXBYTES` while transmitting a packet.
- Reading `WORTIME1` and `WORTIME0` at any time.

3.2.2 How Often Does the Issue Corrupt Read Values?

The probability of reading a corrupt value is given by the frequency with which the read value changes, f_c , and the length of window of uncertainty, T_{WU} (typically 1.3 ns). The probability that the two events overlap, and thus that the read value is potentially corrupted, is given by:

$$P_{\text{corrupt}} = \frac{T_{\text{WU}}}{T_c} = T_{\text{WU}} f_c$$

In the example given in section 3.1, the probability of any single read from `TXBYTES` being corrupt, assuming the maximum datarate is used, is approximately $P_{\text{corrupt}} = T_{\text{WU}} f_c = 1.3 \text{ ns} \cdot (500 \text{ kbps} / 8\text{b}) \approx 80 \text{ ppm}$ or less than once every 10000 reads. In many situations the underlying received packet failure rate in the communication system is so much higher that any packet transmission/reception failure attributable to the issue described here will be negligible.

3.3 Suggested Workaround

In a typical radio system a packet error rate of at least 1 % should be tolerated in order to ensure robustness. In light of this, the negligible contribution to the number of packets lost due to, for example, occasionally reading incorrect FIFO byte count values or the wrong radio state from `MARCSTATE`, can probably be ignored in most applications. However, care should be taken to ensure that reading an incorrect value does not jeopardize an application. Examples of commonsense things to do include:

- For packets longer than the TX FIFO, configure the device to signal on a GDO pin when there is enough room to fill up with a new block of data (using the TX FIFO threshold). If polling `TXBYTES` is necessary due to pin constraints, read `TXBYTES` repeatedly until the same value is returned twice in succession – such a value can always be trusted.
- Always perform a length check on the number of bytes reported in the RX FIFO to avoid a buffer overrun when copying the data to your MCU. A buffer overrun could make your firmware behave erratically or become deadlocked.
- Do not rely on the internal radio state machine through transient states (e.g. `CALIBRATE – SETTling – TX – IDLE`). It is, however, perfectly safe to poll for the end of transmission by waiting for `MARCSTATE = IDLE`.
- Always average RSSI and LQI values over several packets before using them in decision algorithms (e.g. for FH channel selection).
- Avoid using the SPI status byte `STATE` and `FIFO_BYTES_AVAILABLE` fields during packet transmission.

If it is important to **ensure** that read values are not corrupted, reading of one of the affected registers should be done repeatedly until the same value is read twice in succession. If the rate at which the register is read is specified to be at least twice as fast as the expected register update rate, then an upper bound on the number of required reads is four and the average number of reads slightly more than two.

The same method can be used to ensure that the SPI status byte fields that provide simplified radio FSM state and saturated FIFO byte count are correct. This only makes sense when polling the status byte with `SNOP` as the address.

3.4 Batches Affected

This errata note applies to all batches and revisions of the chip.

4 WOR Timing Error on Short Timing Intervals

4.1 Description and Reason for the Problem

The Wake on Radio timer is a very low power timer. It uses a $f_{xosc}/750$ kHz (34.7 kHz with $f_{xosc} = 26$ MHz) clock source for the timer and compare logic. In power down mode this clock source is divided by 128 to achieve a 270.8 Hz clock frequency for the timer, given that f_{xosc} is 26 MHz.

The timer runs on 270.8 Hz in power down to save power. Some time before reaching the programmed timeout value the timer automatically resumes 34.7 kHz operation. This is achieved by pre-incrementing the actual timer value before entering power down mode, to allow match logic to resume 34.7 kHz timer operation.

For timeouts less than approximately 11 ms (detailed timing is shown in application note AN047), the timeout period is too short to switch to the 270.8 Hz clocking scheme. Due to a design error the timer is pre-incremented even if the device does not switch to the 270.8 Hz clocking scheme, effectively shortening the timeout by one 270.8 Hz clock period.

4.2 Suggested Workaround

WOR usage is described in application note AN047 (swra126).

4.3 Batches Affected

This errata note applies to all batches and revisions of the chip.

5 RXFIFO_OVERFLOW Issue

5.1 Description and Reason for the Problem

In addition to having a 64 bytes long RX FIFO, the CC1101 has a one byte long pre-fetch buffer between the FIFO and the SPI module. It also has buffers for status registers, CRC bytes, and buffers used when FEC is enabled. If more than 65 bytes has been received (the FIFO and the pre-fetch buffer is full) without reading the RX FIFO, the radio will enter `RXFIFO_OVERFLOW` state. There are however some cases where the radio will be stuck in RX state instead of entering `RXFIFO_OVERFLOW` state, as it should. Below is a table showing the register settings that will cause this problem. `APPEND_STATUS` is found in the `PKTCTRL1` register, `CRC_EN` is found in the `PKTCTRL0` register, and `FEC_EN` is in the `MDMCFG1` register. `IOCFGx=0x06`, which means that the pin should be de-asserted when the RXFIFO overflows. In the cases where the radio is stuck in RX state, the `GDOx` pin will not be de-asserted.

When the radio is stuck in RX state like this, it will draw current as in RX state, but it will not be able to receive any more data. The only way to get out of this state is to issue an `SIDLE` strobe and then flush the FIFO (`SFRX`).

	# of bytes to be put in RX FIFO	MARSTATE	RXBYTES		GDOx
			RXFIFO_OVERFLOW	NUM_RXBYTES	
<code>APPEND_STATUS = 1</code>	64	IDLE	0	64	OK
<code>CRC_EN = 0</code>	65	IDLE	0	65	OK
<code>FEC_EN = 1</code>	66	RX	0	65	-
	67	RX	0	65	-
	68	RX	0	65	-
	69	RX	0	65	-
	70	RX	0	65	-
	71	<code>RXFIFO_OVERFLOW</code>	1	65	OK
<code>APPEND_STATUS = 1</code>	64	IDLE	0	64	OK
<code>CRC_EN = 1</code>	65	IDLE	0	65	OK
<code>FEC_EN = 1</code>	66	RX	0	65	-
	67	RX	0	65	-
	68	RX	0	65	-
	69	RX	0	65	-
	70	<code>RXFIFO_OVERFLOW</code>	1	65	OK
<code>APPEND_STATUS = 0</code>	64	IDLE	0	64	OK
<code>CRC_EN = 0</code>	65	IDLE	0	65	OK
<code>FEC_EN = 1</code>	66	RX	0	65	-
	67	RX	0	65	-
	68	RX	0	65	-
	69	<code>RXFIFO_OVERFLOW</code>	1	65	OK
<code>APPEND_STATUS = 0</code>	64	IDLE	0	64	OK

CRC_EN = 1	65	IDLE	0	65	OK
FEC_EN = 1	66	RX	0	65	-
	67	RX	0	65	-
	68	RXFIFO_OVERFLOW	1	65	OK
APPEND_STATUS = 1	64	IDLE	0	64	OK
CRC_EN = 1	65	IDLE	0	65	OK
FEC_EN = 0	66	RX	0	65	-
	67	RX	0	65	-
	68	RXFIFO_OVERFLOW	1	65	OK
APPEND_STATUS = 0	64	IDLE	0	64	OK
CRC_EN = 1	65	IDLE	0	65	OK
FEC_EN = 0	66	RXFIFO_OVERFLOW	1	65	OK
APPEND_STATUS = 1	64	IDLE	0	64	OK
CRC_EN = 0	65	IDLE	0	65	OK
FEC_EN = 0	66	RXFIFO_OVERFLOW	1	65	OK
APPEND_STATUS = 0	64	IDLE	0	64	OK
CRC_EN = 0	65	IDLE	0	65	OK
FEC_EN = 0	66	RXFIFO_OVERFLOW	1	65	OK

5.2 Suggested Workaround

In applications where the packets are short enough to fit in the RX FIFO and one wants to wait for the whole packet to be received before starting to read the RX FIFO, for variable packet length mode (`PKTCTRL0.LENGTH_CONFIG=1`) the `PKTLEN` register should be set to 61 to make sure the whole packet including status bytes are 64 bytes or less (length byte (61) + 61 payload bytes + 2 status bytes = 64 bytes) or `PKTLEN ≤ 62` if fixed packet length mode is used (`PKTCTRL0.LENGTH_CONFIG=0`). In application where the packets do not fit in the RX FIFO, one must start reading the RX FIFO before it reaches its limit (64 bytes).

5.3 Batches Affected

This errata note applies to all batches and revisions of the chip.

6 Extra Byte Transmitted in TX

6.1 Description and Reason for the Problem

If one aborts a transmission (exits TX mode) during the transmission of the first half of any byte, there will be a repetition of the first byte of the next transmission. This issue is caused by a state machine controlling the `mod_rd_data` signal in the modulator. This signal asserts at the start of transmission of each full byte, then deasserts after half the byte has been transmitted. If transmission is aborted after a byte has started but before half the byte is transmitted, this signal remains asserted and the first byte in the next transmission will be repeated.

6.2 Suggested Workaround

As long as the packet handling features of the CC1101 are used, this will not be a problem since the chip will always exit TX mode after the transmission of the last bit in the last byte of the packet. If, however, one disables the packet handling features (`MDMCFG2.SYNC_MODE=0`) and wants to exit TX mode manually by strobing IDLE, one should make sure that the IDLE strobe is being issued after clocking out 12 dummy bits (8 dummy bits are necessary due to the tx latency, but since this would mean that transmission is aborted within the first half of a byte, 4 extra bits are added).

6.3 Batches Affected

This errata note applies to all batches and revisions of the chip.

7 Document History

Revision	Date	Description/Changes
SWRZ20B	2009.04.21	Section 6.2. Corrected spelling. Correct is "bits" instead of "bytes".
SWRZ20A	2007.06.30	Initial release.
SWRZ20	2007.04.16	First preliminary release

TEXAS INSTRUMENTS NORWAY

Tel. +47-22958544

Fax +47-22958546

www.ti.com

IMPORTANT NOTICE

Texas Instruments Incorporated and its subsidiaries (TI) reserve the right to make corrections, modifications, enhancements, improvements, and other changes to its products and services at any time and to discontinue any product or service without notice. Customers should obtain the latest relevant information before placing orders and should verify that such information is current and complete. All products are sold subject to TI's terms and conditions of sale supplied at the time of order acknowledgment.

TI warrants performance of its hardware products to the specifications applicable at the time of sale in accordance with TI's standard warranty. Testing and other quality control techniques are used to the extent TI deems necessary to support this warranty. Except where mandated by government requirements, testing of all parameters of each product is not necessarily performed.

TI assumes no liability for applications assistance or customer product design. Customers are responsible for their products and applications using TI components. To minimize the risks associated with customer products and applications, customers should provide adequate design and operating safeguards.

TI does not warrant or represent that any license, either express or implied, is granted under any TI patent right, copyright, mask work right, or other TI intellectual property right relating to any combination, machine, or process in which TI products or services are used. Information published by TI regarding third-party products or services does not constitute a license from TI to use such products or services or a warranty or endorsement thereof. Use of such information may require a license from a third party under the patents or other intellectual property of the third party, or a license from TI under the patents or other intellectual property of TI.

Reproduction of TI information in TI data books or data sheets is permissible only if reproduction is without alteration and is accompanied by all associated warranties, conditions, limitations, and notices. Reproduction of this information with alteration is an unfair and deceptive business practice. TI is not responsible or liable for such altered documentation. Information of third parties may be subject to additional restrictions.

Resale of TI products or services with statements different from or beyond the parameters stated by TI for that product or service voids all express and any implied warranties for the associated TI product or service and is an unfair and deceptive business practice. TI is not responsible or liable for any such statements.

TI products are not authorized for use in safety-critical applications (such as life support) where a failure of the TI product would reasonably be expected to cause severe personal injury or death, unless officers of the parties have executed an agreement specifically governing such use. Buyers represent that they have all necessary expertise in the safety and regulatory ramifications of their applications, and acknowledge and agree that they are solely responsible for all legal, regulatory and safety-related requirements concerning their products and any use of TI products in such safety-critical applications, notwithstanding any applications-related information or support that may be provided by TI. Further, Buyers must fully indemnify TI and its representatives against any damages arising out of the use of TI products in such safety-critical applications.

TI products are neither designed nor intended for use in military/aerospace applications or environments unless the TI products are specifically designated by TI as military-grade or "enhanced plastic." Only products designated by TI as military-grade meet military specifications. Buyers acknowledge and agree that any such use of TI products which TI has not designated as military-grade is solely at the Buyer's risk, and that they are solely responsible for compliance with all legal and regulatory requirements in connection with such use.

TI products are neither designed nor intended for use in automotive applications or environments unless the specific TI products are designated by TI as compliant with ISO/TS 16949 requirements. Buyers acknowledge and agree that, if they use any non-designated products in automotive applications, TI will not be responsible for any failure to meet such requirements.

Following are URLs where you can obtain information on other Texas Instruments products and application solutions:

Products

Amplifiers	amplifier.ti.com
Data Converters	dataconverter.ti.com
DLP® Products	www.dlp.com
DSP	dsp.ti.com
Clocks and Timers	www.ti.com/clocks
Interface	interface.ti.com
Logic	logic.ti.com
Power Mgmt	power.ti.com
Microcontrollers	microcontroller.ti.com
RFID	www.ti-rfid.com
RF/IF and ZigBee® Solutions	www.ti.com/lprf

Applications

Audio	www.ti.com/audio
Automotive	www.ti.com/automotive
Broadband	www.ti.com/broadband
Digital Control	www.ti.com/digitalcontrol
Medical	www.ti.com/medical
Military	www.ti.com/military
Optical Networking	www.ti.com/opticalnetwork
Security	www.ti.com/security
Telephony	www.ti.com/telephony
Video & Imaging	www.ti.com/video
Wireless	www.ti.com/wireless

Mailing Address: Texas Instruments, Post Office Box 655303, Dallas, Texas 75265
Copyright © 2009, Texas Instruments Incorporated